

Cordless Riveter R1B1/R1B2

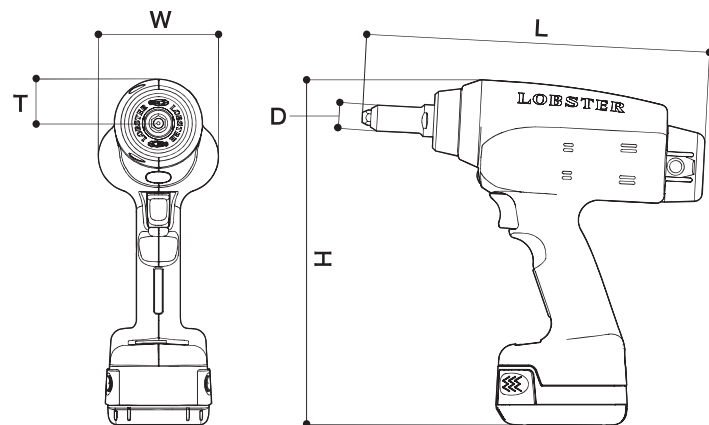

■ Riveter Specifications ※At the time battery pack BPL1415 is installed.

Model	Overall Length (L)	Height (H)	Frame Head Diam. (D)	Width (W)	Weight	(T)	Stroke	Jaw	Compatible Rivets
R1B1	260	260	21.0	90	1.9	33	22	Ultra Jaws'M'	φ 2.4, 3.2, 4.0, 4.8
R1B2	268	260	23.0	90	2.0	33	22	Ultra Jaws'L'	φ 4.8, 6.4 (3.2, 4.0)※

※3.2 / 4.0mm rivets can be used if optional parts are attached. ※6.4mm stainless steel rivets cannot be used.

■ Package Items

Model	Package Item	Code No.	
R1B1	Riveter, battery pack (BPL1415), charger (BC0075G), special case	(230V) 8848	(120V) 8840
R1B2	Riveter, battery pack(BPL1415), charger(BC0075G), special case, nosepiece(4.8, 6.4), sole use wrench	(230V) 8906	(120V) 8902
R1B1-C	※Contact the place of purchase or your nearest "LOBSTER" dealer for the price of R1B1-C and detailed specifications.	(230V) 8876	(120V) 8872



■R1B2 accompanying items



■ Battery Pack Specifications

Model	Type	Voltage Rating	Capacity	Charging Time (※)		Code No.
				Full Charge	Charge for Practical Use	
BPL1415	Li-ion	14.4 V DC	1.5 Ah	60 min	45 min	8860
BPL14	Li-ion	14.4 V DC	3.0 Ah	120 min	90 min	8856

※Full charge: 0% → 100% Charge for practical use: 0% → 80%

■ Charger Specifications

Model	Power	Code No.	
BC0075G	100-240 V AC	(230V) 8900	(120V) 8896

⚠ Caution for secure usage Be sure to read the enclosed Instruction Manual carefully and make sure that you understand them thoroughly before using this tool.

- All dimensions are nominal and subject to tolerances.
- Specifications are subject to change without prior notice.



ACN 23 068 361 455
PO Box 2225, Logan City DC Qld 4114
Website: www.aerofast.com.au
Email: lobster@aerofast.com.au

BRISBANE
8 Booran Drive
Woodridge Qld 4114
Ph: (07) 3299 4555

GOLD COAST
1/13 John Duncan Court
Varsity Lakes Qld 4226
Ph: (07) 5593 4550

SUNSHINE COAST
2/34 Premier Cricuit
Warana Qld 4575
Ph: (07) 5437 7737



LOBSTER LOBTEX CO.,LTD.
International Marketing Group

12-8 Shijo-Cho, Higashi-Osaka City, Osaka 579-8053 Japan
URL : www.riveter.com www.lobtex.co.jp/



Cordless Riveter

R1B1
R1B2

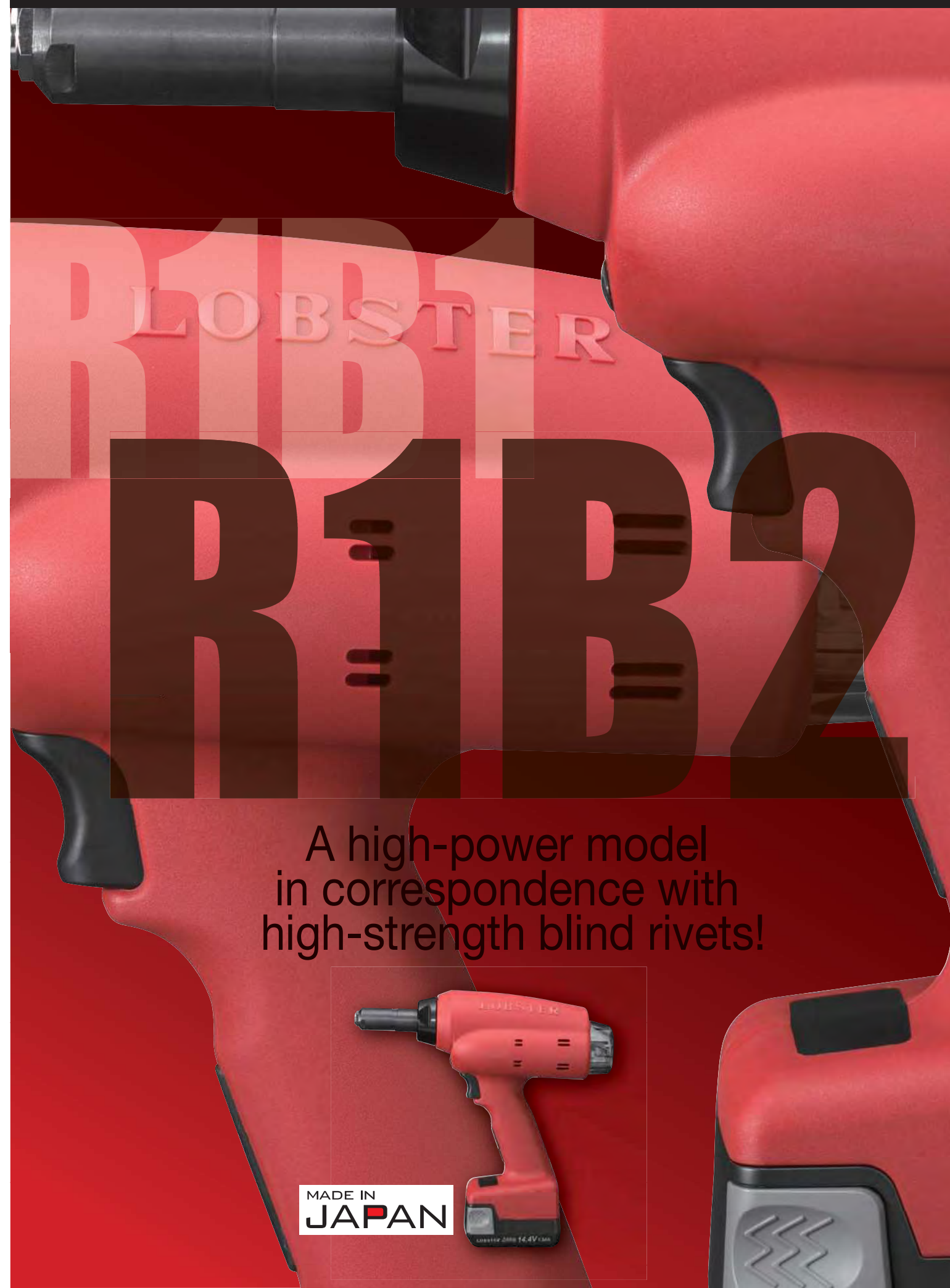

A high-power model
in correspondence with
high-strength blind rivets!



MADE IN
JAPAN



It is not only innovative but also more powerful.

— another new model R1B2 in the series of our high-performance cordless riveter is coming out.

	R1B1	NEW R1B2
Compatible Rivets	Φ2.4/3.2/4.0/4.8	Φ4.8/6.4 (3.2/4.0)*
Stroke	22	22
Number of riveting on a single charge	560*1	560*1

* 6.4mm stainless steel rivet cannot be used.
3.2 and 4.0mm rivets can be used if optional parts are attached.

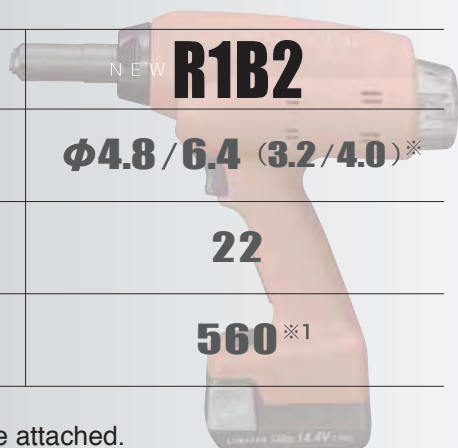

R1B1/R1B2 Product Identity

Energy-saving environmental friendliness

Installs seven times more rivets than possible with conventional model on a single charge. The R1B1 and R1B2 consumes only one forty-fifth of the power consumed by an air riveter thanks to a lithium-ion battery and energy-efficient power transmission system. (*2) This riveting tool installs 560 rivets on a single charge. (*1)

The smallest size and compact body in its class

Lobtex' s unique motor layout realizes more compact body. Moreover, shorter distance between Trigger and riveting section ensures ease of setting a rivet and even excellent operability.

Functionality and aesthetic design

Easy-to-grip, well-balanced design in a fine innovative form the R1B1 and R1B2, the work of product designer Toshiyuki Kita, is implemented in an aesthetically pleasing form with functionality kept strongly in mind. The handle offers a user-friendly grip and is shaped to provide a well arranged weight balance for reduced user fatigue.

Energy-efficient power transmission system

A ball screw that converts rotations efficiently to linear motions and planetary gear that transmits large torques are incorporated to ensure efficient energy transmission and smooth riveting.

High Speed Riveting

Achieves 1.5-second cycle time, placing it in the industry' s fastest class of cordless riveters. Being substantially faster than previous models, the R1B1 and R1B2 helps make your factory "cordless". (*1)

Handling Ease of handling offers less user fatigue after long hours of work

The cordless design gives exceptional ease of operation. The handle is installed at an angle for positioning the tool toward the riveting point with ease. In addition, the tool' s excellent weight balance causes less wrist fatigue after long hours of work. The grip-assist elastomer ensures reliable non-slippery grip for use with gloves.

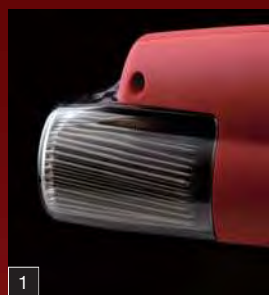

1 Mandrel Collector

Mandrel collector with increased mandrel holding capacity for improved work efficiency

The mandrel collector placed on the side allows for location of mandrel ejection port on the top of the tool. This design is effective for smoothly storing mandrels throughout the collector, resulting in an increased number of mandrels stored during work. Minimal work interruptions make riveting less frustrating.

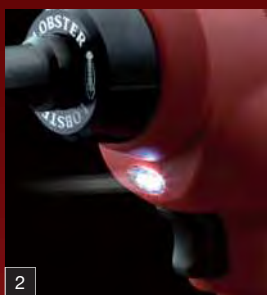

2 LED Spotlight

LED spotlight for precisely illuminating the object

Feel assured even when working in a dimly lit or narrow place. An LED spotlight illuminates the riveting area exclusively.

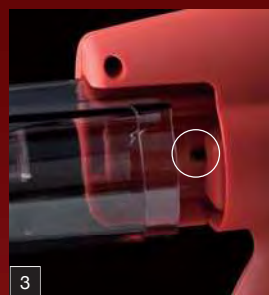

3 Safety Device

Safety device to prevent mandrels from shooting out

In a case where the mandrel collector is dislodged or not fitted properly, a safety device is actuated to interrupt the riveter power supply and disable the trigger. This feature prevents mandrels from shooting out and ensures work safety.



4 Made in Japan Battery

Highly reliable Japanese-made battery

A high-capacity lithium-ion battery, made in Japan, significantly increases the amount of work done during the battery' s life. The R1B1 and R1B2 installs 560 rivets on a single charge. (*1)



5 Ejection Capability

Ejection capability in the event of unexpected operation stoppage

Even if the riveting tool stops working due to battery depletion with a rivet in the process of being clamped, it is possible to remove the rivet by pressing the eject button.

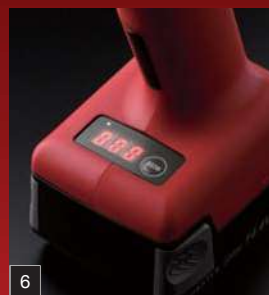

6 Counter

Foolproof system well suited for riveting management

The R1B1 can be supplied with a digital counter (build to order). Unless each riveting cycle is complete, the counter does not advance, enabling the user to minimize overlooked work deficiencies or riveting defects and to achieve foolproof rivet number management.

NEW
R1B2

Designed by product designer
Toshiyuki Kita

(*1) Measurement using 4.8mm stainless steel rivet (NST6-2). (*2) Comparison with the compressor power consumption at the time pneumatic riveter is used.



MADE IN JAPAN tradition

LOBTEX has been manufacturing the products for over 120years in Japan. By continuing Made in Japan tradition, we are providing products to the customers with safety and relief.

Cordless Riveter